

**Typ 40**  
**Serie 40**

**Hebebeschlag für gerades Frontglas**

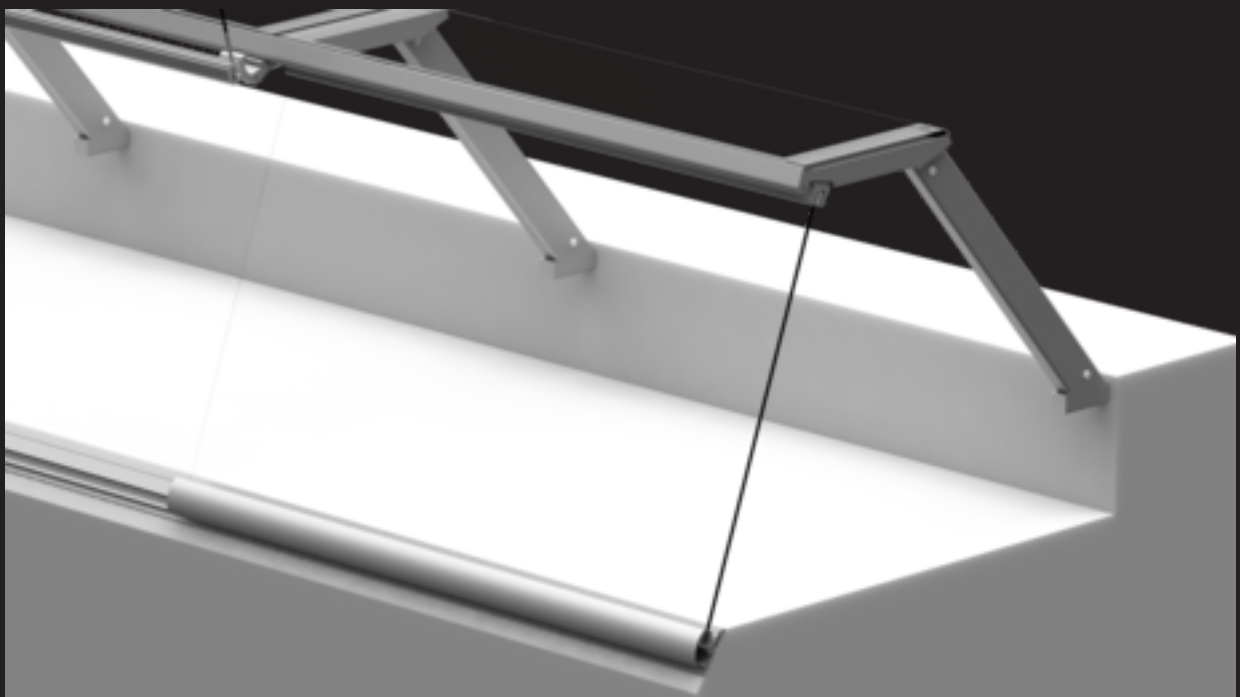

## Planungsinformationen

- Frontglas 6 mm ESG
- Max. Stützenabstand 1600 mm
- Garantie für die Haltbarkeit der Gläser wird nicht übernommen

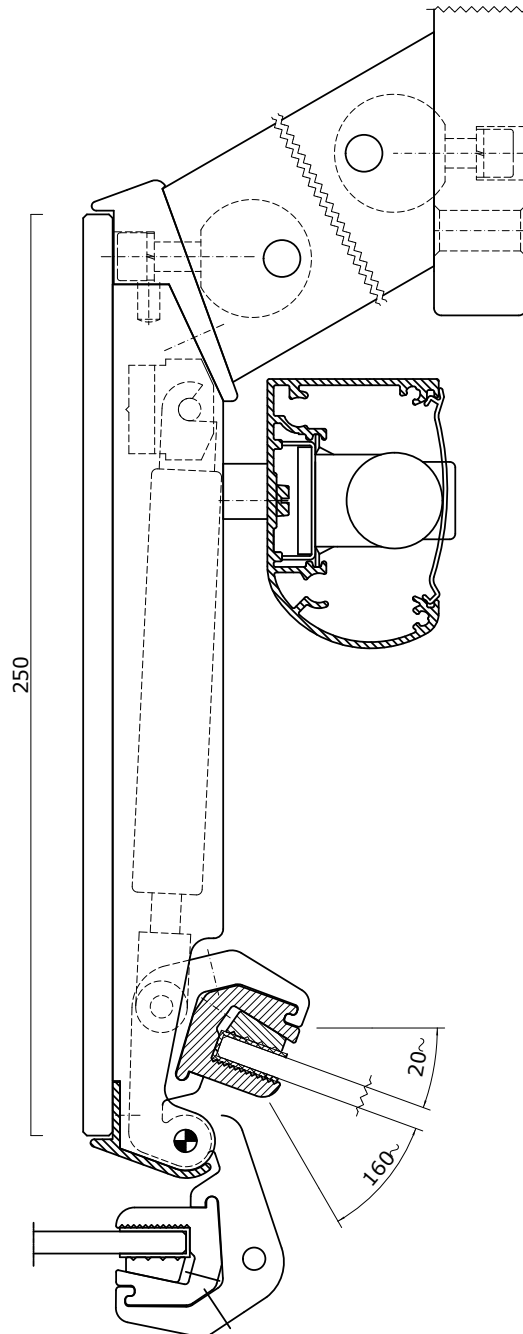

**Typ 40**  
Abbildung

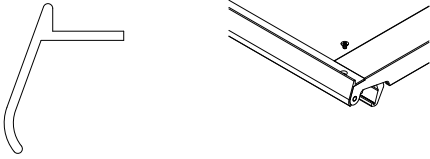
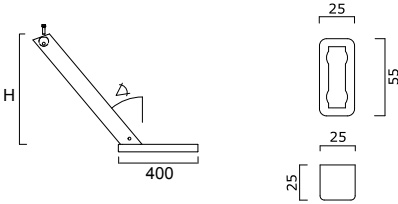
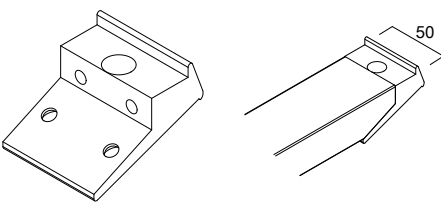
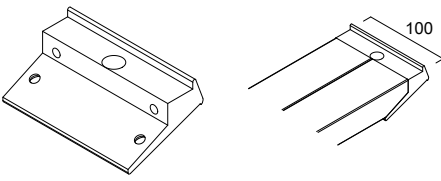
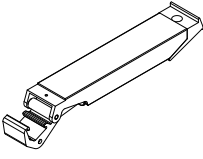
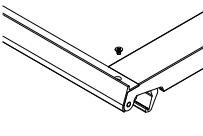
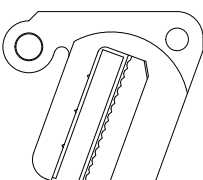
Abbildung	Produkt		Bestell - Nr.
	<b>Frontprofil</b>	5000mm	<b>09.052.3856.XXX</b>
	<b>Stütze</b>	30° 40° 45°	<b>09.442.8124.XXX</b> <b>09.442.8126.XXX</b> <b>09.442.8127.XXX</b>
	<b>Trägeranschlussteil</b>	End	<b>09.441.6590.XXX</b>
	<b>Trägeranschlussteil</b>	Mitte	<b>09.441.6591.XXX</b>
	<b>Träger ohne Gasfeder</b>		<b>09.441.6280.XXX</b>
	<b>Bohrschablone</b>		<b>09.042.0339.XXX</b>
	<b>Glasklemmprofil</b>	5000mm	<b>09.441.6340.XXX</b>

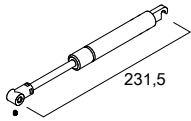
**Abbildung****Produkt****Bestell - Nr.****Gasfeder Lift-O-Mat**300 N  
400 N  
500 N  
600 N  
700 N**09.441.6712.040**  
**09.441.6713.040**  
**09.441.6714.040**  
**09.441.6715.040**  
**09.441.6716.040****Bohrvorrichtung**Senkbohrungen in Frontprofil  
zur Befestigung auf Träger**08.042.0339.000**